

(115 GT / 120 GTA)

(115 GTC / 120 GTAC)

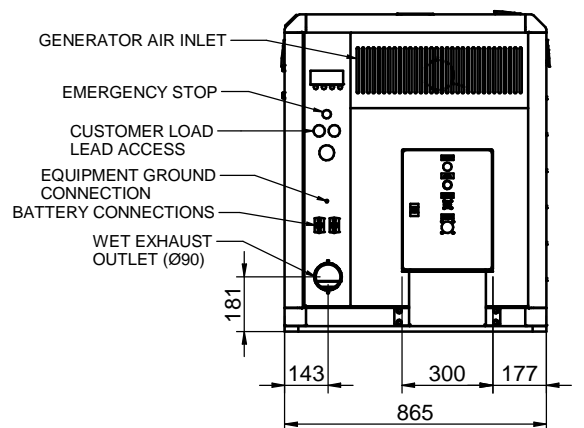
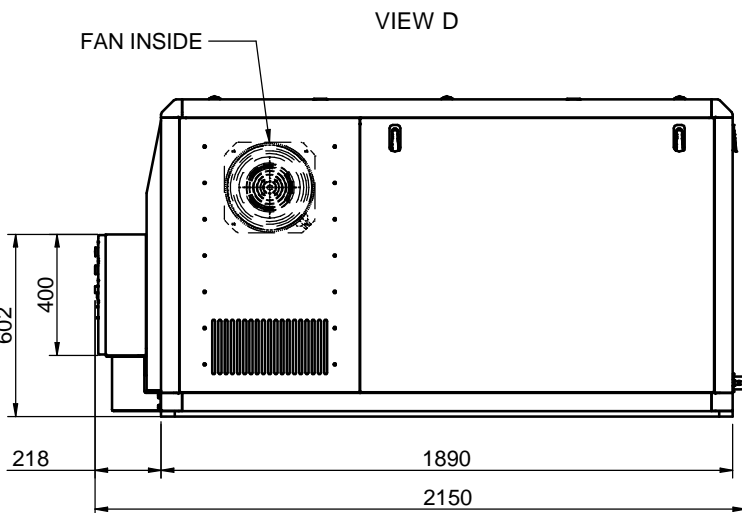
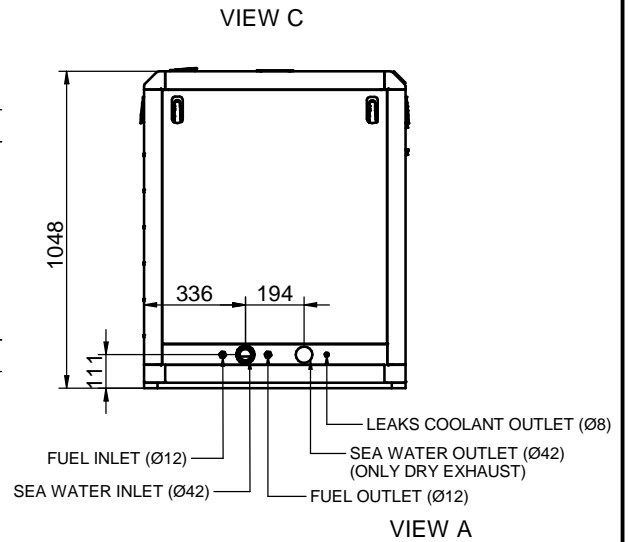
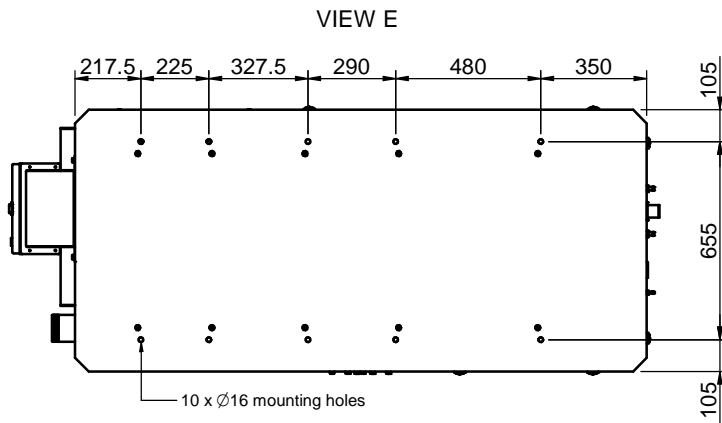

Medidas Nominales (mm)	100	GRUPO 115 GT-115 GTC PARALELO / 120 GTA-120 GTAC PARALELO				
	a	300	GENSET 115 GT-115 GTC PARALLEL / 120 GTA-120 GTAC PARALLEL			
Grado de Precisión DIN-7168	6	±0.15	±0.2	±0.5	±1.2	
	a	±0.1	±0.2	±0.3	±0.8	
Fino	6	±0.05	±0.1	±0.2	±0.5	
	a	±0.05	±0.1	±0.2	±0.5	
Medio	6	±0.1	±0.2	±0.3	±0.8	
	a	±0.1	±0.2	±0.3	±0.8	
Basto	6	±0.2	±0.5	±1.2	±1.2	
	a	±0.2	±0.5	±1.2	±1.2	
		DIBUJADO	VERIFICADO	GRADO PRECISIÓN	FECHA CREACIÓN	ÚLTIMA REVISIÓN
		VICTORG	P.IGLESIAS		10/12/2021	01/01/2022
					SOLÉ, S.A.	
					FA0774/FA0776 FA1444/FA1478	