

MARINE ENGINE

SDZ-205

6 cylinders In line 196.0 CV (143.9 kW) 2300 Max RPM

Technical specifications

Base engine manufacturer	Deutz
Type	Diesel, 4 stroke
Number of cylinders	6, In line
Intake system	Turbocharged
Bore x Stroke	108 mm x 130 mm (4.25 in x 5.12 in)
Total displacement	7146 cc
Compression ratio	17.5:1
Intermittent power _{SN_ (ISO3046/1)}	196.0 CV (143.9 kW)
Continuous power	176.0 CV (129.5 kW)
Max RPM	2300
Injection system	Mechanical and direct
Starter motor	24 V (4 kW)
Alternator	55 A (24 V)
Maximum operating angle	10 °
Rotation (viewed from flywheel side)	Counterclockwise
Cooling system	Sea water heat exchanger and coolant closed circuit
Dry weight without gearbox	650 Kg (1433.0 lb)
Sea water hose inner diameter	42 mm (1.65 in)
Fuel feeding hose inner diameter	12 mm (0.47 in)
Fuel return hose inner diameter	12 mm (12 in)
Exhaust hose inner diameter	125 mm (4.92 in)
Certifications and emissions	-
Emission compliance	No emissions

Performance curves

Crankshaft torque

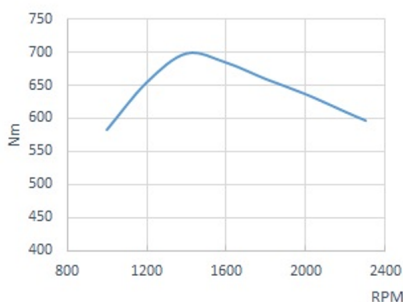

Power (ISO 3046/1)

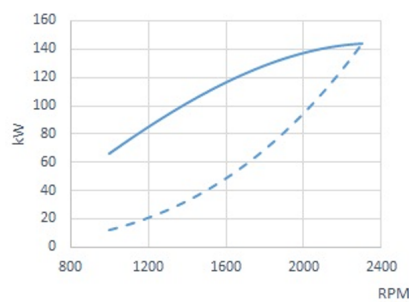

Fuel consumption

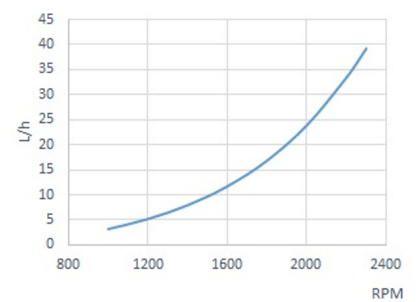

Panel



Dimensions: 255 x 160mm

Panel SSG 30 Panel 24V White Standard

Revolution counter with multifunction display

Coolant temperature and oil pressure gauge

Voltage indicator and battery charge fault

High coolant temperature alarm

Low oil pressure alarm

Preheating indicator

Front IP65 protection and anti-fog glass

5-position key

Accessories

Standard equipment

Instrument panel SSG 30

4 m electrical extension lead

Oil extraction pump

Owner's manual and spare parts manual

Optional equipment & kits

Twin instrument panel installation

Twin alternator

Earth isolated electrical system

Dry exhaust system

Keel cooling

Power takeoff shaft or pulley

Calorfier Connections

Drivetrain: propeller, shaft, stern tube

Water and fuel filters

Water, exhaust and die

Gearboxes

Model	Type	Output °	Reductions (light Duty)	Reductions (heavy Duty)	Engine weight w/gbox
DMT-100HL	Hydraulic	0°	-	4.07:1-4.50:1-4.95:1-5.29:1-5.95:1	926 Kg (2042 Lbs)
TM-1200A	Hydraulic	7°	2.30:1	2.30:1	776 Kg (1711 Lbs)
TM-170	Hydraulic	0°	1.50:1-2.04:1	-	735 Kg (1621 Lbs)
TM-200B	Hydraulic	0°	-	3.60:1-4.48:1	898 Kg (1979 Lbs)
TM-880A	Hydraulic	10°	1.53:1-2.08:1	-	714 Kg (1574 Lbs)

Dimensions

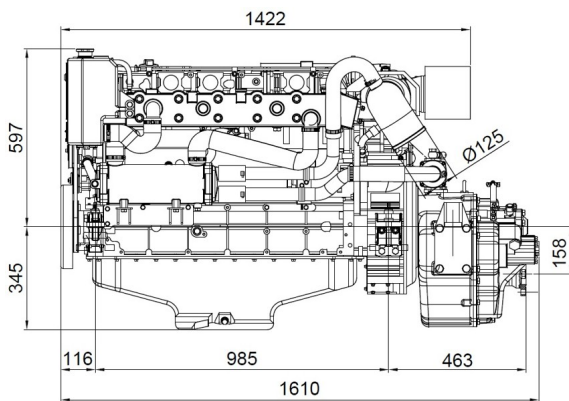

SDZ-205 24V Engine TM-265 2.09:1 Gbox.CF

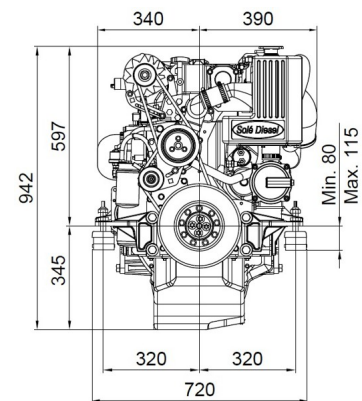

Authorized dealer



Detailed drawings, brochures and manuals are available on the web soleadvance.com. All rights reserved. Technical specifications, data and presentation are subjected to variations, changes and updates without prior notice. Non-contractual information.

