

# L13-SERIES

500ps [368kW] per ISO 3046

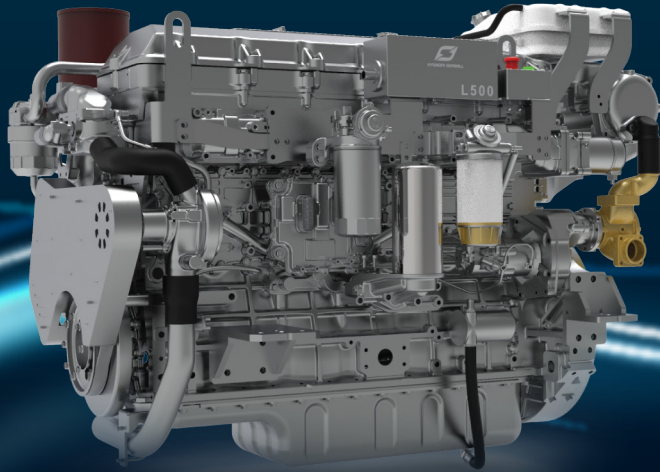

## 12.7 Liter Heavy Duty Commercial Engine

The Electronic Unit Injection system delivers 500ps and 232kg-m of torque from the 12.7 liter in-line 6 cylinder engine.

The robustly-designed unit was specifically conceived as a heavy duty engine with the ability to serve the professional and commercial markets. It has stable performance at high load and responds well to sudden load changes.

Excellent power and torque in a wide rpm range proves Hyundai SeasAll's diesel development capabilities are world-class and beats the performance of competition's comparable models. Economy is assured by the state-of-the-art fuel management system featuring electronic unit injectors (EUI).

## Technical Descriptions

### Engine

- 6 cylinder in-line, 24-valve OHC
- Cast iron cylinder block and cylinder head
- Gallery oil-cooled long lasting mono steel pistons
- Integrated water jacket
- Single serpentine belt system
- Drive belt auto-tensioner

### Engine Mounting

- Adjustable engine mounts (Optional)

### Lubrication System

- Gear-driven engine oil pump
- Closed system with forced feeding
- Integrated oil-cooler in cylinder block
- Easily exchangeable oil filter cartridge
- Eco type oil filter
- Washable auxiliary cyclone oil filter
- Electric oil extraction pump

### Fuel System

- Electronic Unit Injector (EUI)
- Gear-driven fuel pump
- Electronically controlled injection timing
- Fine fuel filter and water separator
- High pressure six-hole injector nozzles

### Electrical System

- 24 volt – 90A alternator
- Auxiliary engine stop button
- Air heating system for a trouble-free cold start
- NMEA2000 Converter (Optional)
- 2 Pole system (Optional)

### Cooling System

- Gear-driven seawater pump
- Seawater-cooled intercooler, heat exchanger
- Auxiliary connector for cabin heating
- Corrosion resistant material for seawater circuit
- Easily accessible rear mounted sea-water pump

### Exhaust System

- Coolant cooled exhaust manifold
- Cast iron exhaust pipe
- WGT (Waste Gate Turbocharger)

### Instrument Box Assembly



- Engine self-protection and diagnosis
- Displays CAN information
- Displays engine diagnostic error codes
- Audible alarm and control lamps
- Idle & PTO rpm adjustable switch

### Air Inlet system

- Reusable air filter
- Intake Extension Kit (Optional)

### Emissions

- US EPA Tier-III
- IMO Tier-II (EIAPP)
- CCNR II

## Scope of Supply

	RATINGS <sup>1</sup>	OM	IBA <sup>2</sup>	SeasLink***	BC**	DEP	SWP	TWO-POLE*	IEK**	NMEA 2000 C	SSS
L500	S1	●	●	○	●	●	●	○	○	○	○

OM=OPERATION MANUAL  
IEK=INTAKE EXTENSION KIT\*\*

IBA=INSTRUMENT BOX ASSEMBLY (WITH EOI)  
C=CONVERTER

BC=BELT COVER

DEP=DRY EXHAUSTED PIPE

SWP=SEA WATER PUMP

### 1. RATINGS

**S1** HEAVY DUTY COMMERCIAL

**S2** MEDIUM DUTY COMMERCIAL

**S3** LIGHT DUTY COMMERCIAL

### 2. INSTRUMENT BOX ASSEMBLY includes

EOI BOX, RPM GAUGE and WIRING HARNESS

● : Standard    ○ : Option    : N/A  
S = Sterndrive    P = Propeller Shaft    J = Water Jet  
G = For Generator    Pr = Prime Power    Sb=Stand-by

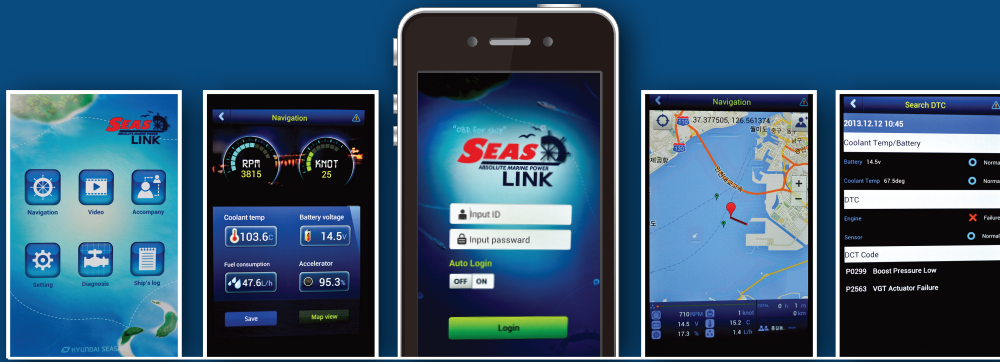

## ON THE SMARTER PHONE

- Displays Engine Information
- Displays Boat Track on the Map
- Monthly User's Log Information
- Engine Diagnostic Functions
- Audible Warning Alarm and Visual Pop-up Screen



## Specifications

Engine Type	L500
Propulsion system	Shaftdrive & Waterjet
Engine Duty Rating	Heavy Duty (S1)
Configuration	4-Stroke, 24-Valve OHC WGT with Intercooler, Fresh Water Cooling
Output [ps (kW)]	500 (368)
Rated rpm	1,800
Cylinders	In-line 6
Displacement [cc]	12,736
Bore X Stroke [mm]	130 X 160
Compression Ratio	16 : 1
Max. Torque @ rpm	232.0kg-m @1,200rpm
Injection System	Electronic Unit Injector (EUI)
Alternator	24V-90A
Engine Diagnostics	YES
Max Fuel Consump. [l/h]	89.2
Dry Weight [kg]	1,310
Flywheel	SAE 14
Flywheel Housing	SAE 1

## Performance Curves

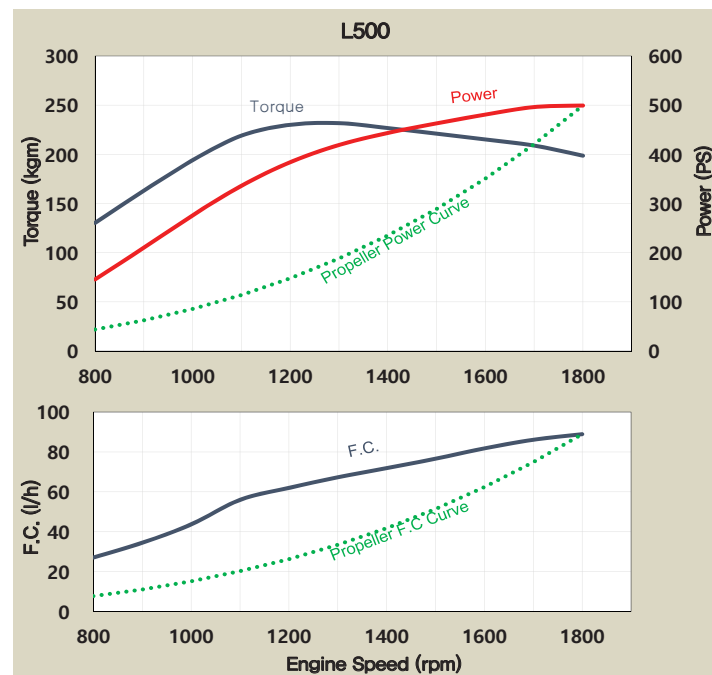

## Dimensions (mm)

